

RCD

DINI ARGEO DIGITAL COLUMN LOAD CELL, IN STAINLESS STEEL, "RCD" SERIES



Digital version of compression load cells, ideal for CE-M approved weighbridges, tanks, silos, etc. Manufactured in STAINLESS STEEL, with IP68 protection, 4000 divisions, fitted with "rodent proof" armoured cable.

CAPACITIES (kg): 30000/40000/50000.

OIML R60. C4 precision class.

Load cells with stainless steel body. Degree of protection IP68.

18m Armoured Rodent Resistant Cable, with standard Stainless Steel Armor.

Low Profile Height of only 130mm.

The best solution
for advanced industrial
applications

TECHNICAL FEATURES

- METROLOGICAL:
- Rated capacity (Cn): 30/40t
- Combined error: $\pm 0,014 \%Cn$
- Temperature effect on zero: $0,0016 \%Cn/^{\circ}C$
- Temperature effect on sensitivity: $0,0012 \%Cn/^{\circ}C$
- Creep error (30 min.): $0,021 \%Cn$

LEGAL METROLOGY OIML R60

- Accuracy class: C4
- Max. number of intervals (nmax): 4000e OIML
- Minimum verification interval (vmin): 10000
- $Z = E_{max}/(2 \times DR)$: 4000

ELECTRICAL

- Nominal range of excitation voltage: 10 - 16Vdc
- Rated output: 200000d
- Current consumption: 35mA
- Conversion type: Delta-sigma
- Internal resolution: 24 bit
- Converter rate: max. 100 conv./sec.
- RS485 interface communication rate: 4800/19200 bit/sec.
- Protection against electrostatic discharge according to IEC 61326-1

GENERAL

- Service temperature range: $-20 \sim +60^{\circ}C$
- Compensated temperature range: $-10 \sim +40^{\circ}C$
- Safe load limit: 150% E_{max}
- Ultimate overload: 300% E_{max}
- Protection degree IP68
- Load cells with stainless steel body
- 6-core armoured cable, PVC sheath, 18m length, 9mm diameter.
- Nickel plated steel cable gland.
- Armoured Anti Rodent Cable with Stainless Steel Armour.
- Self-centring spherical bases.
- Equipped with anti-rotation system, to be combined with KRCA cups for proper operation.

MAIN CERTIFICATIONS

- OIML R60
- Australian legal for trade certificate of approval (NMI S842)

WIRING CODE

•

RCD cell connections	
<i>Colour</i>	<i>Function</i>
Input	
WHITE	EXC +
BROWN	EXC -
GREY	IN A +
PINK	IN B -
GREEN	OUT A +
YELLOW	OUT B -
YELLOW-GREEN	SHIELD

RCD LOAD CELL: INSTALLATION KIT

- The KRCA kit allows a correct installation of the RCD load cells below the weighbridge plate.
- The kit consists of an upper cup with anti-rotation system, a lower cup and a two-hole plate for easier and faster fixing. All components are made from nickel-plated steel.
- Both cups are designed for optimal operation in conjunction with the cell's self-centring spherical bases, allowing their proper oscillation and return to position.
- The cups are also fitted with triple function integrated washers:
 - they keep lubricating grease in its place.
 - they simplify the proper positioning and levelling of the cell and support it during installation/maintenance.
 - they protect the system by preventing dirt and water from accumulating on the bottom of the cup, thus maintaining the correct oscillation and mechanical compensation of the load cells over time.

DETAIL 1

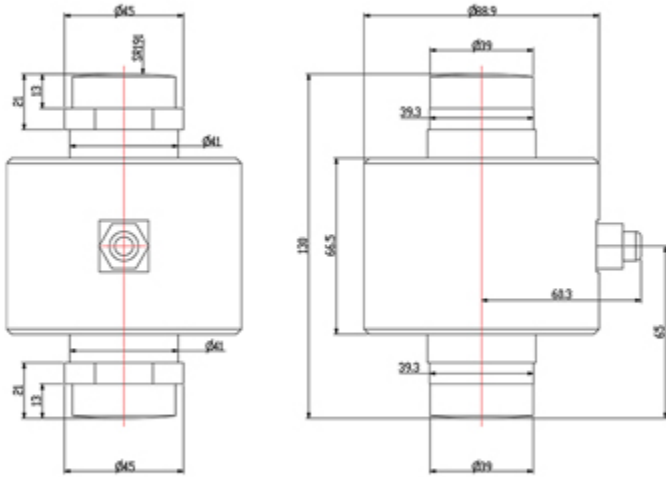

Technical drawing in mm.

DETAIL 2



RCD load cell complete with optional KRCA kit.

DETAIL 3

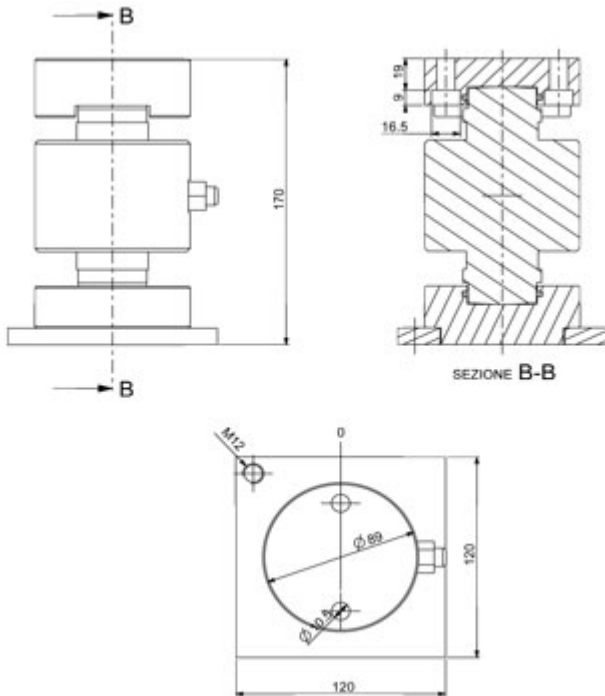

Technical drawing in mm with optional KRCA kit.

DETAIL 4



VERSIONS

Available versions

Code		Max (kg)
RCD30C4		30000
RCD40C4		40000
RCD50C4		50000



“YOUR WORLDWIDE PARTNER FOR WEIGHING”

DINI ARGEO
FRANCE sarl
France

DINI ARGEO
GMBH
Germany

DINI ARGEO
UK Ltd
United Kingdom

DINI ARGEO WEIGHING
INSTRUMENTS Ltd
China

DINI ARGEO
OCEANIA
Australia



COMPANY HEADQUARTERS

Via Della Fisica, 20
41042 Spezzano di Fiorano Modena • Italy
Tel. +39.0536 843418

SERVICE ASSISTANCE

Via Dell'Elettronica, 15
41042 Spezzano di Fiorano Modena • Italy
Tel. +39.0536 921784

SALES AND TECHNICAL ASSISTANCE SERVICE